



Solid State



XFP range

1 or 2 loop EN54 networkable
analogue addressable fire panels



XFP

range



XFP single loop 16 zone panel



XFP 1 or 2 loop 32 zone panel

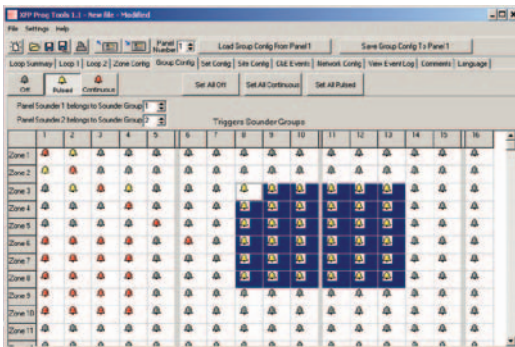

Sophisticated sounder group mapping (above) and complex cause and effect scenarios (below) can be easily implemented using the XFP's intuitive upload-download programming software.

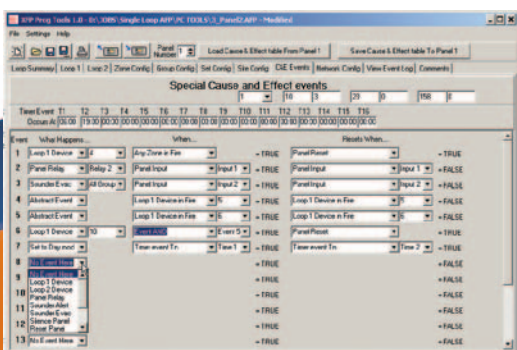

Fully compliant with EN54 parts 2 & 4, C-TEC's new range of networkable analogue addressable fire panels offer high performance at a very competitive price.

Available in two different versions (a cost-effective single loop 16 zone panel in a plastic enclosure and a robust 1 or 2 loop 32 zone metal panel), they offer an array of user and installer-friendly features, including:-

- ▶ Full compatibility with Hochiki's ESP and Apollo's XP95, Discovery and Xplorer protocols
- ▶ The ability to interconnect up to eight XFP main panels (any variant) plus an additional four XFP repeaters per main onto two wire RS485 networks
- ▶ Two independently programmable conventional sounder circuits
- ▶ Two programmable inputs
- ▶ A fault output relay and three programmable relay outputs with voltage free changeover contacts
- ▶ A selection of zone dependency/coincidence functions (allows zones to be individually programmed to be Type A, B or C. Selecting 'Type A' sets the zone up so no action will be taken on the first detected alarm unless there is confirmatory signal from another zone. Selecting 'Type B' sets the zone up so the first detected alarm will be indicated, but a full fire condition will only be established if there is a confirmatory signal from the same zone. Selecting 'Type C' sets the zone up so the panel enters a fire condition on the first detected alarm but certain outputs are inhibited until a confirmatory alarm).
- ▶ A day/night (building occupied/unoccupied) function (allows the operational characteristics of the panel to be changed at a pre-determined time. Engineer programmable day/night changes include detector sensitivity (high/low) and zone dependency settings)
- ▶ An investigation delay period function (programmable for length of time, which zone(s) it applies to and whether or not it operates in day/night mode)
- ▶ Individual sensitivity settings for each device
- ▶ A phased evacuation facility
- ▶ An alarm counter that records the number of times the panel has been in an alarm state (to meet clause 7.13 of EN54-2)
- ▶ Powerful short circuit protected loop drivers, capable of supporting up to 40 loop powered 10mA sounders per loop
- ▶ An integral EN54 switch mode PSU rated @ 185-260V a.c. 50/60Hz (1.4A on 16 zone panel, 3A on 32 zone panel)
- ▶ Adjustable contamination levels
- ▶ Earth fault monitoring
- ▶ Push button access code or keyswitch entry to Access Levels 2 and 3 (depending on model purchased)
- ▶ An easy to read, 80 character back-lit display
- ▶ 40 characters of custom text per device
- ▶ 999 event monitoring
- ▶ Comprehensive test, maintenance & commissioning functions (including auto-learn loops, monitor a point, test outputs, one man walk test and loop continuity test)
- ▶ An intuitive Windows based upload-download PC program that allows the system to be programmed quickly and easily

SINGLE LOOP 16 ZONE XFP PANELS

XFP501E/X; XFP501EK/X
XFP501E/H; XFP501EK/H

ONE OR TWO LOOP 32 ZONE XFP PANELS

XFP501/X; XFP501K/X; XFP502/X; XFP502K/X;
XFP501/H; XFP501K/H; XFP502/H; XFP502K/H

Power Supply Specification

Mains supply voltage	230V a.c. \pm 10% 50/60Hz	230V a.c. \pm 10% 50/60Hz
Internal power supply	27V d.c Nominal	27V d.c Nominal
Total output current limited to	1.4A @ 230V a.c.	3A @ 230 V a.c.
Supply and battery charger monitored for failure	Yes	Yes
Batteries monitored for disconnection and failure	Yes	Yes
Batteries protected against deep discharge	Yes	Yes
Max. battery size and type	3.2 Ahr VRLA	7.0 Ahr VRLA
Quiescent current drain (1 loop unloaded)	< 50mA	< 80mA
Quiescent current drain (2 loop unloaded)	not applicable	<100mA
Earth fault monitoring	Yes (any conductor)	Yes (any conductor)
Temperature compensated charging	Yes	Yes

Loop Driver Specification

Number of loop drivers	1	1 (XFP501/X ; XFP501K/X; XFP501/H ; XFP501K/H) 2 (XFP502/X; XFP502K/X; XFP502/H; XFP502K/H)
Line monitored for open and short circuit faults	Yes	Yes
Onboard loop isolators with LED indication when active	Yes	Yes
Auto-polling from each loop end	Yes	Yes
Max. loop output current	500mA	500mA
Max. number of addressable devices per loop	126	126
Max. number of loop powered sounders per loop @ 10mA	40	40
Number of programmable sounder groups	15	15
Number of programmable output sets	16	16

Conventional Sounder Circuit Specification

Number of programmable circuits	2	2
End of line resistor value	6800 Ω 5% Tol. 0.25 W	6800 Ω 5% Tol. 0.25 W
Line monitored for open and short circuit faults	Yes	Yes
Outputs fused at	400mA	500mA
Max. number of sounders @ 20mA	40	50

Auxiliary Outputs

Type	Relay voltage free single pole changeover	
Max switching current	1A	
Max switching voltage	30 V d.c	
Relay 1	Programmed from cause and effect	
Relay 2	Programmed from cause and effect	
Relay 3	Programmed from cause and effect	
Fault	Active when no faults are present	
24V Aux Power Output	100mA. Protected by resettable overload circuit.	

Auxiliary Inputs

Input 1	Connect to 0V to trigger. Max input voltage 27V d.c. (non-latching). Programmable from cause and effect.
Input 2	Connect to 0V to trigger. Max input voltage 27V d.c. (non-latching). Programmable from cause and effect.

Fuses (to IEC - EN60127 Pt2)

Mains Fuse	1A HRC Ceramic 20mm
Battery Fuse	3A F 20mm

Panel Indicators and Controls

Control buttons	Silence, Reset, Resound, Investigate; More Information; Menu	
Event scrolling and menu access buttons	Up (1); Down (2); Accept (3); Abort (4)	
Liquid Crystal Display	Two lines x 40 characters, backlit	
Number of Zonal LED indicators	16	32
Other LED indicators	General Fire, System Energised; Pre-Alarm; Remote Output Activated; Menus Accessed; Disablement; Test; Remote Output Disabled; Silenced; General Fault; System Fault;	

Physical Dimensions

Approx. dimensions of back box (W x H x D)	380 x 235 x 77mm (plastic). Includes 'lip'.	410 x 250 x 80mm (metal)
Approx. dimensions of lid (W x H x D)	380 x 235 x 16mm (plastic)	439 x 274 x 7mm (metal)
Approx. weight (without batteries)	1.9Kg	4.5kg

Cabling Requirements

Type of cable	Fire resistant screened cable, minimum size 1mm ²	
Max. cable length per loop	1 KM	
Connector blocks	Plug-on type, largest acceptable conductor size 1.5mm ²	
Max. allowable loop impedance (each conductor)	20 Ω	
Max. cable capacitance	.27 μ F	

Network Specification

Connection	Via CFP761 network driver card fitted at main panel	Via AFP711 network driver card fitted at main panel
Max. no. of main panels per network	8	8
Max. no of repeaters per main panel	4	4
Max. cable length per network	1KM (daisychain configuration)	1KM (daisychain configuration)

PC/Printer Interface

PC connection	Via main panel RS232 molex connector (lead supplied in XFP507 upload/download software kit)	
Printer connection	Not applicable	Via main panel RS232 connector block.

TYPICAL WIRING

Below is a diagram of a typical XFP analogue addressable loop fitted with a selection of detectors, loop powered sounders, modules and isolators, all connected to an XFP single loop 16 zone panel. The diagram also illustrates how a series of XFP fire panels can be networked together using the range's powerful RS485 network.

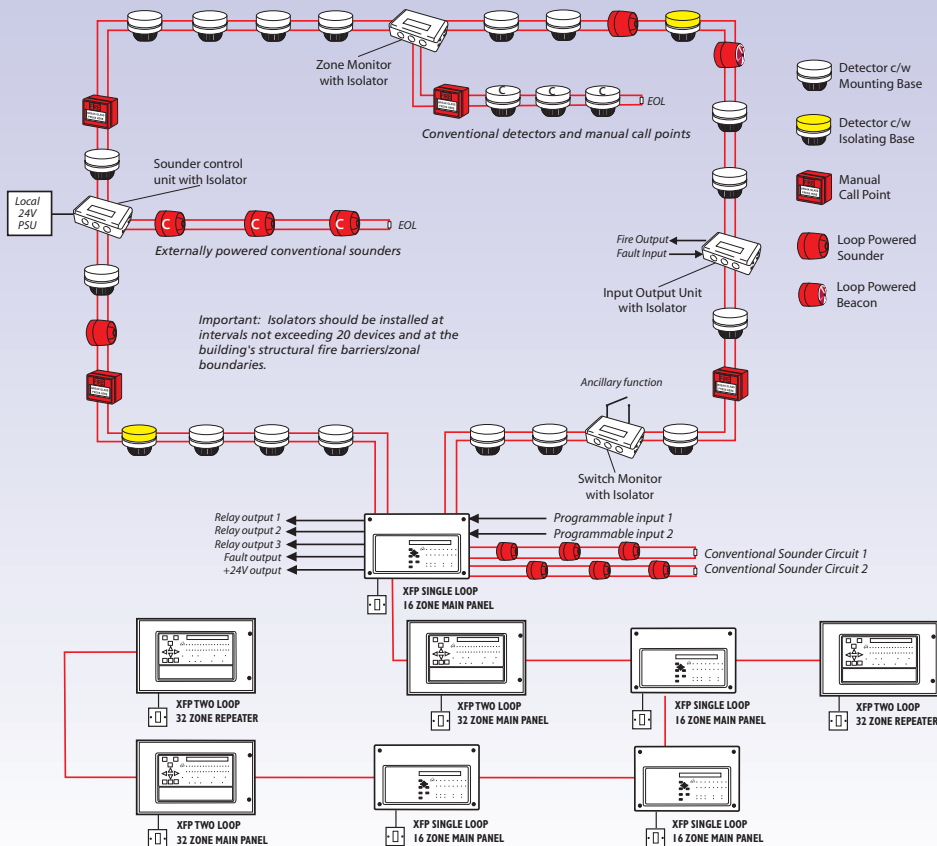

The above diagram is provided for illustration purposes only and you should always refer to the relevant XFP panel/device instructions as appropriate before installation. Note that the descriptions and availability of the devices shown may not be applicable to all manufacturer's protocols.

KEY FEATURES OF XFP NETWORK PROTOCOL

- ▶ Supports eight interconnected XFP panels over a two-wire RS485 network.
- ▶ Single loop 16 zone XFPs and 1 and 2 loop 32 zone XFPs may be networked together.
- ▶ Any main panel can have up to four repeaters connected to it.
- ▶ Up to 1 km of cable may be fitted to a network system.
- ▶ Each networked XFP panel can be programmed to:
 - Accept Faults from other panels.
 - Accept Fires from other panels.
 - Accept Control actions such as silence control sounder, silence alarm sounders and reset from other panels.
 - Accept Disablement commands for zones, sounders and output sets from other panels.
 (Each of these four functions may be individually selected).
- ▶ All panels monitor all other panels for network wiring faults.
- ▶ Fires on remote panels are displayed in detail on a local panel including the point description of the origin of the alarm.
- ▶ Faults on remote panels are displayed in detail on a local panel including the point description in the case of a detector.
- ▶ Cause and effect can be programmed into a local panel dependent on which remote panel is in alarm.
- ▶ The network supports programming of site information into remote panels from a PC connected at a local panel.
- ▶ Time and date is common to all panels throughout the network.
- ▶ All panels connected to the network need a network driver card.

XFP ORDER CODES

XFP SINGLE LOOP 16 ZONE FIRE PANELS

XFP501E/X	XFP Networkable single loop 16 zone panel (XP95/Discovery) Code entry, c/w 1.4A psu, plastic enclosure
XFP501EK/X	XFP Networkable single loop 16 zone panel (XP95/Discovery) Keyswitch entry, c/w 1.4A psu, plastic enclosure
XFP501E/H	XFP Networkable single loop 16 zone panel (Hochiki ESP) Code entry, c/w 1.4A psu, plastic enclosure
XFP501EK/H	XFP Networkable single loop 16 zone panel (Hochiki ESP) Keyswitch entry, c/w 1.4A psu, plastic enclosure

XFP 1 LOOP 32 ZONE FIRE PANELS

XFP501/X	XFP Networkable one loop 32 zone panel (XP95/Discovery) Code entry, c/w 3A psu, metal enclosure
XFP501K/X	XFP Networkable one loop 32 zone panel (XP95/Discovery) Keyswitch entry, c/w 3A psu, metal enclosure
XFP501/H	XFP Networkable one loop 32 zone panel (Hochiki ESP) Code entry, c/w 3A psu, metal enclosure
XFP501K/H	XFP Networkable one loop 32 zone panel (Hochiki ESP) Keyswitch entry, c/w 3A psu, metal enclosure

XFP 2 LOOP 32 ZONE FIRE PANELS

XFP502/X	XFP Networkable two loop 32 zone panel (XP95/Discovery) Code entry, c/w 3A psu, metal enclosure
XFP502K/X	XFP Networkable two loop 32 zone panel (XP95/Discovery) Keyswitch entry, c/w 3A psu, metal enclosure
XFP502/H	XFP Networkable two loop 32 zone panel (Hochiki ESP) Code entry, c/w 3A psu, metal enclosure
XFP502K/H	XFP Networkable two loop 32 zone panel (Hochiki ESP) Keyswitch entry, c/w 3A psu, metal enclosure

XFP REPEATERS

XFP510	XFP Networkable repeater panel, 32 zones (all protocols) Code entry, c/w psu, metal enclosure
XFP510K	XFP Networkable repeater panel, 32 zones (all protocols) Keyswitch entry, c/w psu, metal enclosure

XFP BEZELS

AFP385	Flush mounting bezel (for XFP 32 zone panels & repeaters)
	XFP 16 zone panels have been designed so they can be surface or semi-flush mounted without the need for an additional bezel

XFP NETWORK COMMUNICATION CARDS

CFP761	XFP network communication card for XFP 16 zone panels All protocols, one required for each networked panel
AFP711	XFP network communication card for XFP 32 zone panels All protocols, one required for each networked panel

XFP PROGRAMMING SOFTWARE

XFP507	XFP Upload download software kit (all protocols) Compatible with Windows 98, 2000, XP
--------	---

XFP PRINTER KITS

AFP709	XFP off-board printer kit
--------	---------------------------



Solid State Security Limited,
Hartfield House,
54 Chorley Road, Hilldale, Parbold,
Wigan, Lancashire WN8 7AS.
United Kingdom.

+44 (0) 1257 463018
+44 (0) 1257 462038
sales@solidstatesecurity.co.uk
www.solidstatesecurity.co.uk